



SPEED & TIME MEASURING INSTRUMENT MODEL TS-107

MODEL TS-107 IS A MEASURING INSTRUMENT TO MEASURE SPEED & TIME WITH HIGH PRECISION. THIS MACHINE CAN MEASURE TIME & SPEED OF ALL THE PRODUCTS CONCERNED WITH TIME AND SPEED SUCH AS AUTOMOBILE, AND TIME IN SPORTS.

Features

- TIME RANGING FROM 1/100000 sec. (0.1ms) TO 1,000,000 sec. (11.5 DAYS) AND SPEED RANGING FROM 0.01m/s TO 10000 km/h CAN BE MEASURED. (STANDARD SPECIFICATIONS)
- PRINTING OUT OF DATA AND DATA COLLECTION BY PERSONAL COMPUTER IS POSSIBLE. (OPTIONS)
- A VARIETY OF SENSOR ASSORTMENT IN ACCORDANCE WITH USAGE. MAX.4 ASSORTMENTS ARE POSSIBLE.
- 2-POWER SOURCE SYSTEM, AC POWER SOURCE AND BATTERY DC-12V MAKES IT POSSIBLE TO USE OUTDOORS.
- YOU CAN ASSORT AND MAKE AN ORDER-MADE SYSTEM VERY EASILY IN ACCORDANCE WITH USAGE.

Specifications

- TIME MEASUREMENT : 0.01ms to 999999s (6 RANGES)
- SPEED MEASUREMENT : 0.01m/s to 100000km/h (72 RANGES)
(MIL/h,mm/s is available as option)
- ACCURACY : $\pm 1 \times 10^{-5}$ OPTION : $\pm 1 \times 10^{-6}$, $\pm 1 \times 10^{-8}$
- MEASURING TIME : 6 DIGIT TIME COUNTER, ORIGINAL OSCILLATOR 100KHz
- MEASURING SPEED : SPEED IS DISPLAYED AFTER MEASURING PASSING TIME BETWEEN 1 PAIR OF SENSORS BY CALCULATION. (CPU:Z-80)
- MEMORY : NIL, (OPTION=8ch)
- DISPLAY : 6 DIGIT, RED LED, LETTER HEIGHT : 15mm
- SENSOR : 1 to 4 ASSORTED PHOTO SENSORS OR CONTACT INPUT
(O.C IS POSSIBLE)
- DISTANCE AMONG SENSORS : 6 KINDS,
(ONLY MEASURING SPEED) 2m, 1m, 0.5m, 0.1m, 20mm, 10mm
- OUTPUT : PRINTER : CORRESPONDENT TO CENTRONIX
RS-232C : 1ch(25pin),9600bps
- POWER SOURCE : AC 100/120/220/DC 12V ABOUT 20W
- DIMENSIONS : (W)240 x (D)370 x (H)100mm
- USING CONDITIONS : TEMP, 0 to 40°C, HUMIDITY 20 to 80%RH
- ACCESSORIES : AC CORDx1, DC POWER CORDx1, INSTRUCTION MANUALx1

SENSOR IS SOLD SEPARATELY.

THE SPECIFICATIONS MAY BE CHANGED WITHOUT NOTICE.

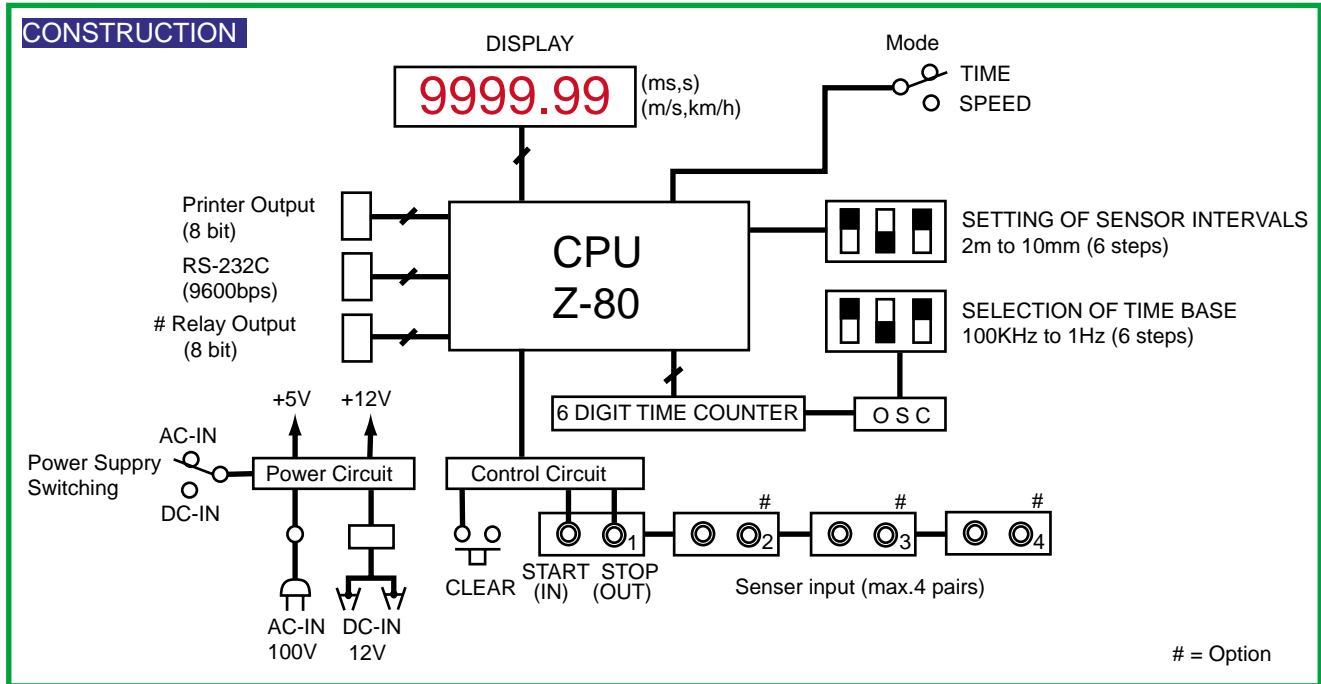

APPLICATIONS (incl. Optional use)

MEASUREMENT OF SPEED

[MAKERS OF AUTOMOBILES AND 2-WHEELED VEHICLES]

- CAR SPEED MEASUREMENT IN TEST COURSE. (FOR DEVELOPMENT)
- CAR SPEED MEASUREMENT DURING CAR NOISE MEASUREMENT. (FOR CAR SPEED CERTIFICATION)
- MEASUREMENT OF CLOSING SPEED OF CAR DOOR. (FOR DESIGN OF CAR DOOR & Q.C.)
- CAR SPEED IN COLLISION EXPERIMENT. (SAFETY, Q.C.)

[DRIVER'S LICENSE, OFFICIAL RATINGS, TRAINING SCHOOL]

- SPEED CHECK OF CARS AND 2-WHEELED VEHICLES.

[SPORTS]

- MEASUREMENT OF INITIAL SPEED OF GOLF BALL & GOLF CLUB HEAD SPEED.

MEASUREMENT OF TIME

[SPORTS]

- FOR TRAINING OF SPRINT IN FIELD TRACK.
- FOR TRAINING OF SWIMMING.
- FOR TIME CHECK OF SLALOM AND DESCENT IN SKIING & DATA TOTALIZATION IN SPORTS EVENTS.
- TIME MEASUREMENT & DATA TOTALIZATION IN MARATHON & LONG-DISTANCE RACE.

[BUSINESS]

- MEASUREMENT OF MOTION TIME OF MACHINES & EQUIPMENT.
- MEASUREMENT OF TIME IN EXPERIMENTS OF PHYSICS AND CHEMISTRY.
- MEASUREMENT OF TIME IN TV & RADIO BROADCASTING PROGRAM OR IN COMPILATION OF BROADCASTING PROGRAM.

SENSOR (INPUT)

MAX. 4 PAIRS OF SENSORS CAN BE CONNECTED AND ALSO VARIOUS ASSORTMENT IS POSSIBLE.

- CONTACT POINT INPUT OF MICRO SWITCH, OPEN COLLECTOR INPUT.
- INFRARED PHOTO SENSOR. (10mm to 50m, reflection type is also possible)
- LASER TYPE PHOTO SENSOR. (100mm to 100m, reflection type is also possible)
- OTHER TYPES OF SENSORS.

ORDER-MADE SYSTEM CAN EASILY BE CONSTRUCTED. PLEASE FEEL FREE TO CONTACT US.

THESE SPECIFICATIONS ARE SUBJECT TO CHANGE WITHOUT NOTICE.